

Dams Gate Control Using Programmable Logic Controller and SCADA

Avinash Kumar, Vipin Kumar Pal, Vinay Kumar Chaurasiya, Ajay Singh

Department of Electrical Engineering, Meerut Institute of Engineering and Technology, Meerut, Uttar Pradesh, India.

Article Info

Article history:

Received 23 January 2021

Received in revised form

28 June 2021

Accepted 5 July 2021

Available online 15 September

2021

Keywords: Programmable logic controller, supervisory control and data acquisition, float sensor, level sensor, ladder logic, function block.

Abstract: This paper is focused on the automation of gates of dam with using the current smart technologies of Programmable Logic Controller (PLC) and SCADA. A dam is an artificial reservoir made to collect a huge volume of water across a river or water body and use it for the purpose of generation of electricity, irrigation, water conservation and stream regulation. Due to uneven rainfall in India, it is not possible for some areas to get regular supply of water or due to their geographical conditions a huge amount of water runoff. So, water collected in the dam is very essential for these areas. Hence, it is necessary to make dams gates automatic for the wise use of available water resource, and increase efficiency of dams that would result in best commercial, agricultural and social benefits. A large number of dams in the world still uses manual system for the controlling of gates of dam, which employs humans for the desired operation, that may have the chances of human error resulting in improper regulation of the stream and also decreases the overall efficiency. To overcome these problems an Automation system is essential that comprises of PLC and SCADA to control the gates of dam by using a single system operation. The operations of dam gates are based on the feedback signals from the level sensors (Digital Input) and float sensor (Analog Input). The forward and reverse operation of dc motor of gates is achieved with the PLC. Ladder programming is used to implement the whole operations of this system. SCADA is used for remote monitoring for a number of dams from a central controlling station.

1. Introduction

PLC is a controller which is used for the controlling operation of machinery and manufacturing processes[1]. PLC is used for the automation of the industries. Automation is the use of technology to produce maximum output with the minimum interaction of human. It increases the efficiency and productivity of the industry. A PLC uses ladder programming for the controlling of various operations in the industries. HMI & SCADA with PLC increases the overall handling process on a single screen[2]. For automation, PLC is very important required tool of all industries as it reduces the dependency on labour and also reduces the chances of errors. SCADA provides some additional features to the PLC that is SCADA is very effective method to monitor the gates of the dam according to the level of water[3]. It also records the data of the water level on a single screen. These data are very important for the forecasting and evaluation of the future requirements. With the help of SCADA, we can monitor all the task from a single room (control room) in any situation. PLC is user friendly as it's logic and programs are very easy than the normal programming languages. PLC's are generally used where high reliability and fast response is required with easy programming like as manufacturing plant, ore processing plant etc. PLC's can be used over wide range of inputs and outputs.

Ladder programming is used for giving the instructions to the PLC. Ladder logic is the most common method for programming in PLC[7]. Ladder logic is a graphical PLC programming language which is used to express logic operations with figurative notations using ladder diagrams, much like the rails and rungs of a traditional relay logic circuit. With the arrival of microprocessor and origination of PLC, relay logic rapidly replaced by programming languages like as ladder logic. It is used by engineers and electricians to execute logical sequential, timing, counting and arithmetic tasks in order to carry industrial automation process. Recent advancement in software technology means that PLC programming using ladder logic has been extended into counting, PID control, arithmetic sequencers, data manipulation function etc. The use of ladder diagrams makes these whole things very simple because we can use simple diagrams to fulfil our requirements according to the task.

Automation is very important factor for any industry at this time. It is rapidly growing technology which can be used in mostly all fields of the plants such as machine controlling field, medical field, maintenance field etc. In this project, automation has been used for

Corresponding Author,

E-mail address: avinash.kumar@miet.ac.in

All rights reserved: <http://www.ijari.org>

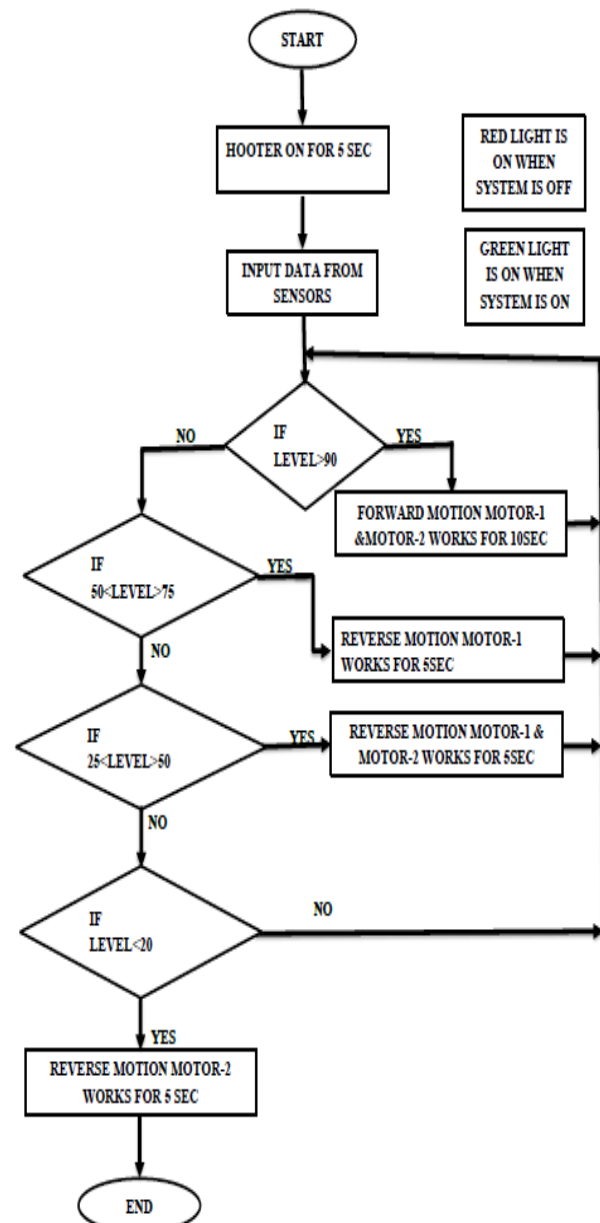

Fig. 1: System flow chart.

the controlling of the gates of dam with sensors as input and PLC [5]. To increase the features of project model we have used the pc system and PLC for giving the inputs.

2. Flow Chart-System Overview

There are some important tools and systems which are very useful for this model.

PLC is heart of this system. All the operations are done by the PLC. We have implemented the automation in SIEMENS-SIMANTIC S7-1200 model. There are 14 digital inputs and 2 analog inputs and 10 digital outputs. The analog input uses sensors of 0-10 VDC and 4-20 mA current rating. The size of work memory available in this PLC is 100 KB.

2.2 SCADA

We use SCADA for getting the data from devices and switches in system so that we can display it on PC. Hence it can be monitored and controlling can be done. SCADA also help in providing graphical presentations of the two gates when they open or close with help of DC motor. The logic can be made with the help of SCADA in which data and time is recorded.

2.3 Buzzer and LED

Buzzer and LED are used for giving alarm to the people timely. LED will be turned ON and buzzer will make buzzing sound as water level increases above the mentioned level in the Program.

2.4 Level Sensors and Floating Sensor

Level sensors will be put inside fixed to check the water level. Floating sensors is also used for getting the actual position of water level. As the water level is increased the sensing element will sense the level and operation will be done by the PLC according to the level through which the Sensor is connected.

2.5 Relays for Controlling of Gates

The system uses two Double Pole Double Throw (DPDT) relays for controlling of the motor direction according to the level of water level input by the sensors to the PLC. The forward and reverse moment of the motors control the operations of gates.

3. Ladder Program Execution

- i. Level sensor (20), refers to the water level at 20% of the reservoir.
- ii. Level sensor (90), refers to the water level at 90% of the reservoir.
- iii. %MD5, refers to the water level input from the float sensor.
- iv. Pulse timer are used for counting the time of the operation of motor for the forward and reverse moment of the gates.
- v. Hooter is used as a delay operator for the whole system.

3.1 %FB1

Function block 5 uses a Ladder Logic to take input from the level sensor(90) and uses a timer for gate operation.

3.2 %FB2

Function block 2 uses data input from the analog sensor.

3.3 %fB3

Function block 3 uses a Ladder Logic for the initiation of the whole program, measures water level from the float signal and scale it according to the reservoir of dam.

3.4 %FB4

Function block 4 uses a Ladder Logic to take input from the level sensor(20) and uses a timer for gate operation.

3.5 %Q0.5 and %Q0.6

are used as the terminals for forward operation of both the motors.

3.6%Q0.7

is used for the reverse operation of the gate motor-1 while %Q0.1 is used for the reverse operation of gate motor-2.

4. Opertaion

When the main switch is turned on, green light is also turned ON to show that the whole system is in operating mode. And hooter is turned ON for 5 sec and after that the sensors give input signal to the PLC.

If the level sensor connected at 90% of the water level gives the input signal to be high than the motor-1 and motor-2 operates in forward direction for 10sec. Hence, opening the full gates. If the water level drops to the range of more than 50 but less than 75 than the motor-1 operates for 5sec in reverse direction. Hence, closing gate-1 to half while gate-2 is completely opened.

If the water level drops to the range of more than 25 but less than 50 than motor-1 operates for 5 sec in reverse direction completely closing gate-1. While motor-2 operates for 5sec in reverse direction closing gate-2 to half. If the level sensor connected at 20% of the

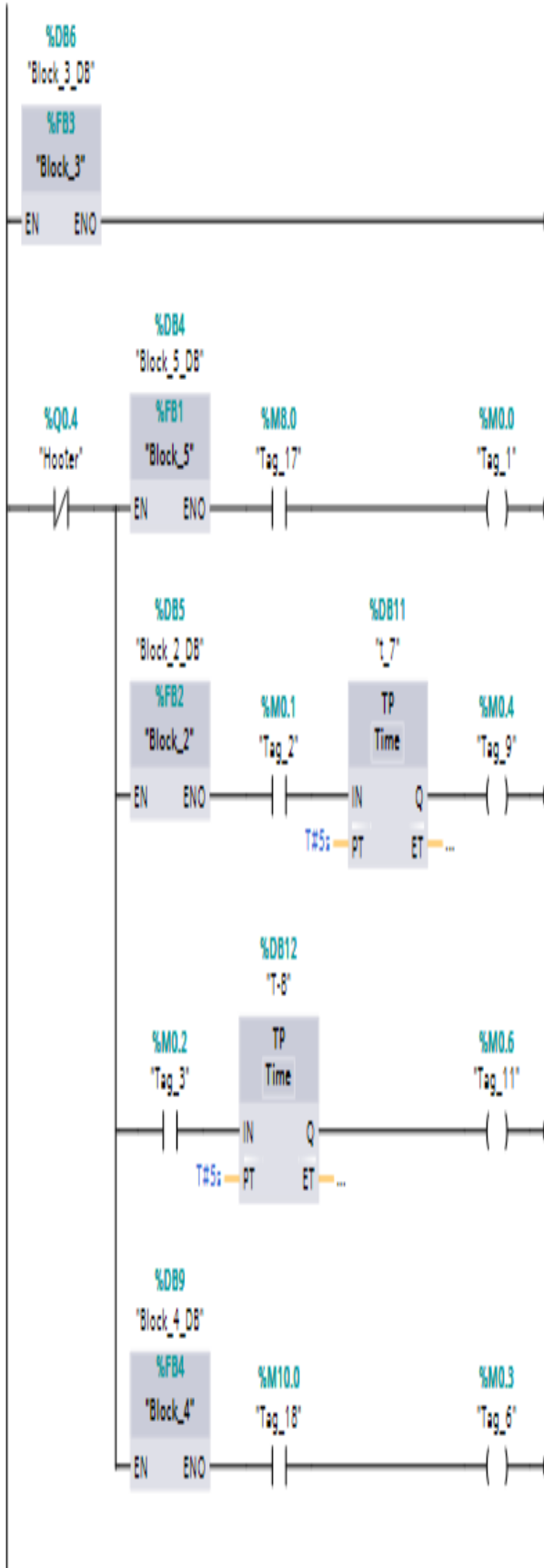

Fig. 2: Ladder program for the system

2.1 PLC

water level gives the input signal to be high than the motor-2 operates for 5 sec in reverse direction. Hence, closing the gate-2 completely.

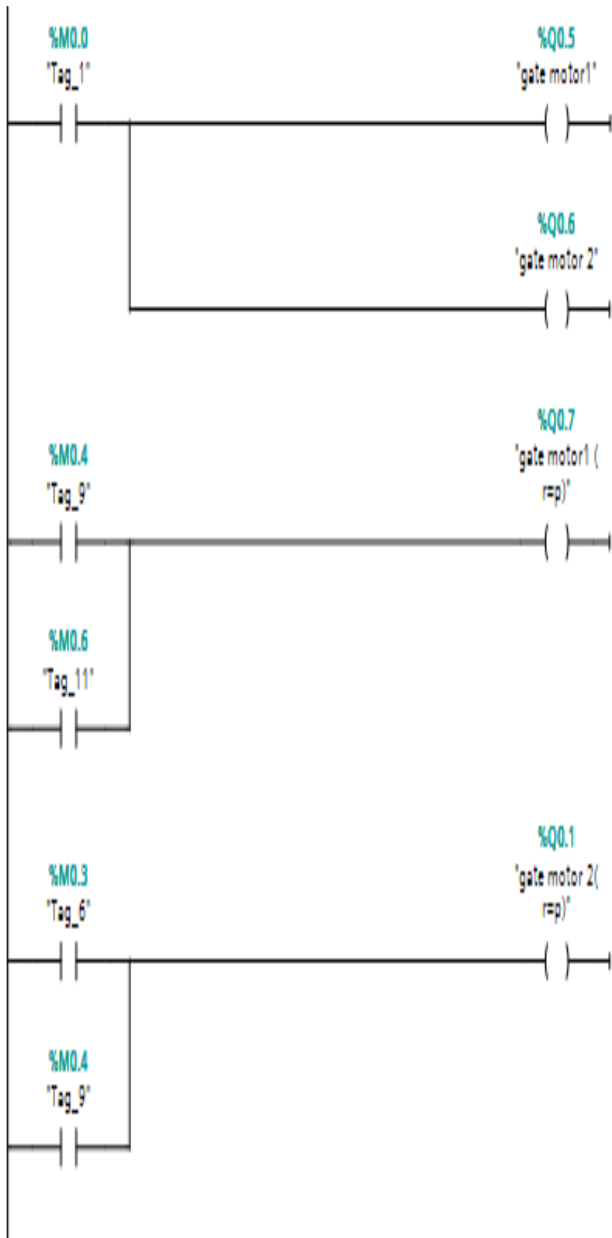

Fig. 3: Output port of the system.

4.1 SCADA DISPLAY

Supervisory control and data acquisition system is used for remote operation of the controlling system of dam gates operations[3]. A Human Machine Interface (HMI) is used is to display the status of the water level and also the visual screen shows the operation of various components of the system. HMI can also be used to change the state of the main switch of the system.

The various states of the whole system can be seen in the figure 4, illustrating the visual view of the whole system.

4.2 Results

The automation of gates has been implemented in SIEMENS-SIMANTIC S7-1200 module. The ladder programming has made the controlling of gates very easy. The flowchart of this system is an initiative for future plans of small and large hydro-electric power plant projects. This project is focused on the human safety and concerns for the global environment conservation, through the appropriate use of the water. It also fulfils the desired goals of hydro-electric power plant project.

PLC system provides automation through rigid control enforcement, to eliminate human errors and to minimize manual interventions. PLC system is easy to maintain and control. They are

economically good and simple to operate[6]. The system has following advantages for future:



Fig. 4: HMI visual display

- Easy operator interface due to colour graphic and advisory system introduction.
- Analog signal handling and close-loop control programming.
- This model will increase the application by using other high-level sensors and controllers.
- For actual position of water, different methods can be used like as GPS, level sensors, Capacitor theory etc.
- This paper will enhance the automation technique in any fields.

5. Conclusions

In this research paper, it shows that motors are automatically controlled with the help of sensors and PLC. This model is helpful for the controlling of gates of dam. It is completely automatic by using the controlling of gates with PLC and feedback from the level sensors. So According to the water level, the gates of dam operate. This method is very effective for the saving of water. When the level of water increases it opens the gates and with the decrease of water level, it compares its position and performs accordingly i.e., opening and closing of gates of the dam. Thus, the use of PLC has opened doors for the automation of several fields effectively. There are various advantages of this model like as water supply in

villages, industrial applications, household applications. Main advantage of this model is to control the gates in emergency situations. It records the data of water level so that the forecasting of the dam controlling can be done according to the time, month, season.

Refernces

- [1]. V Sahu. Automation of Gates of Water Reservoir Using Programmable Logic Controller (PLC), *Int. J. Res. Appl. Sci. Eng. Technol.*, 6(4), 2018, 3924–3927. doi: 10.22214/ijraset.2018.4644.
- [2]. RR Sorte et al., PLC based Dam Automation System, 2(3), 2015, 5–8.
- [3]. Kale, P Moon, C Jadhav, V Patil, K Jadhav, R Shinde. Distant Monitoring and Controlling of Gated Dams using PLC and SCADA, *Int. Res. J. Eng. Technol.*, 6(4), 2019, 2900–2903.
- [4]. G Saha, A Pama, R Sushmitha, S Bhat. Automatic floodgates control using PLC with added focus on human safety, *Int. Conf. Control Instrum. Commun. Comput. Technol. ICCICCT 2015/16*, 417–422. doi: 10.1109/ICCICCT.2015.7475315.
- [5]. I Madanhire, M Madaka, C Mbohwa. Design of an automated dam shutter control system: Case study, *Proc. Int. Conf. Ind. Eng. Oper. Manag.*, 7, 2018, 2627–2639.
- [6]. MT Oo, T Thin. Gate Control System of Dam using Programmable Logic Controller, 6(5), 2019, 224–228.
- [7]. www.ladderlogicworld.com
- [8]. www.siemens.com